

# D-CUT<sup>®</sup>

## OPERATION MANUAL

---

PVC Flooring Cutter LT-200

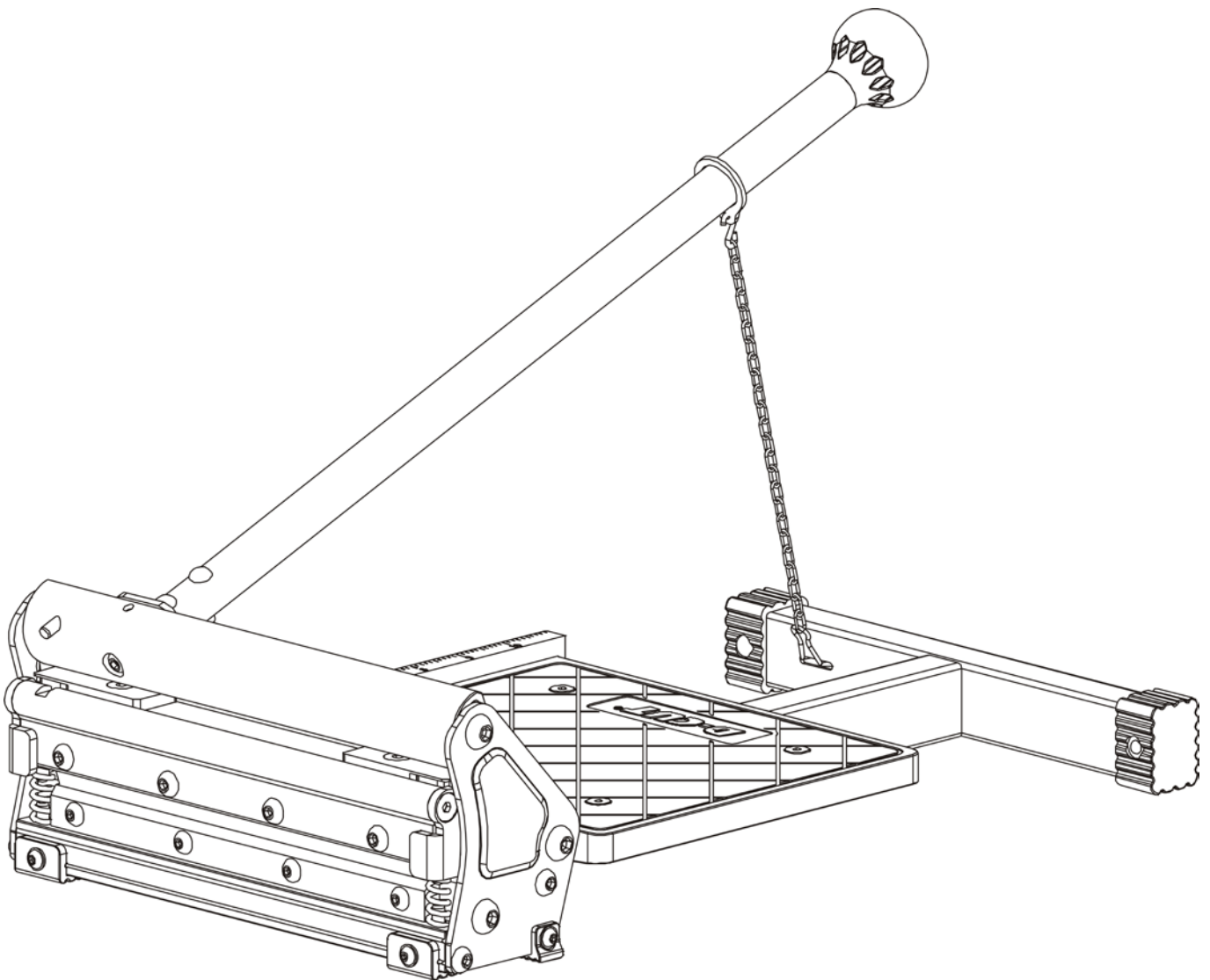



**WARNING: FAILURE TO FOLLOW THESE RULES MAY RESULT IN SERIOUS INJURY! USING THIS MACHINE WITH RESPECT AND CAUTION WILL CONSIDERABLY LESSEN THE POSSIBILITY OF PERSONAL INJURY.**

---

## **SAFETY RULES FOR THE FLOORING CUTTER**

- 1. READ AND UNDERSTAND THIS INSTRUCTION MANUAL BEFORE OPERATING THE D-Cut MULTI-FLOORING CUTTERS.**
2. If you are not thoroughly familiar with the operation of D-Cut Multi-flooring Cutter, obtain advice from a qualified instructor or call 800-982-3434 USA
3. Stay alert. Do not operate while under the influence of drugs, alcohol, or medication.
4. Always wear safety approved eye protection with side shields(ANSI Z87.1)
5. Keep work area free of debris.
6. Keep children and unauthorized persons away from the D-Cut Multi-flooring Cutter and work area.
7. Make sure tool is secure. Operate only on a firm substrate or solid stand.
8. Use the right tool. Do not force the D-Cut Multi-flooring Cutter or use it for a job for which it was not designed; use only on approved materials.
9. Keep the blade sharp. A dull blade will not perform properly.
10. Always keep hands away from blade while operating or carrying the cutter.
11. Do not alter or misuse this tool. The D-Cut Multi-flooring Cutter is precision built; modifications not specified in this manual may result in a dangerous and unsafe environment.
12. Maintain the D-Cut Multi-flooring Cutter with care. Keep Blade sharp and clean. Follow instructions for changing accessories.
13. Use only recommended accessories. The use of improper accessories may be hazardous and cause injuries.
14. Never leave the D-Cut Multi-flooring Cutter unattended. Secure the handle with the lock chain when not in use.

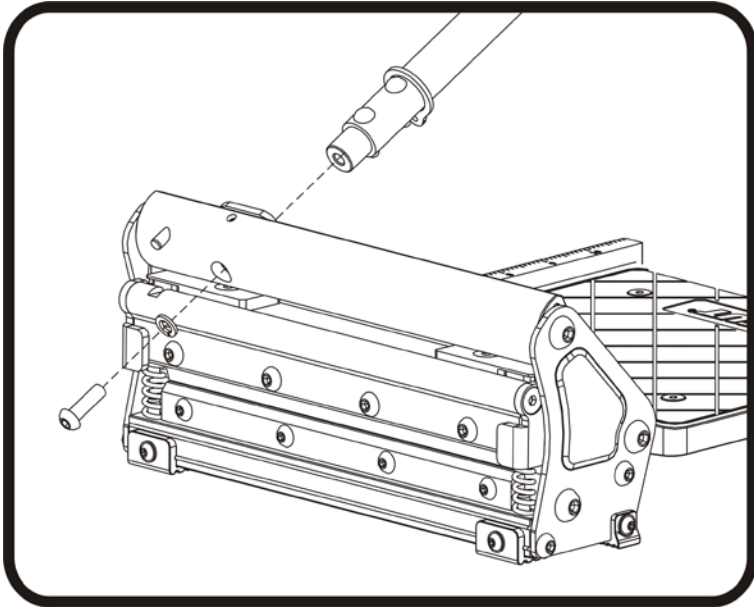

### Installation of the Cutter

Insert the handle base into the handle as shown.

**Warning:** Do not put your fingers against the sharp edge of the blade at any time.

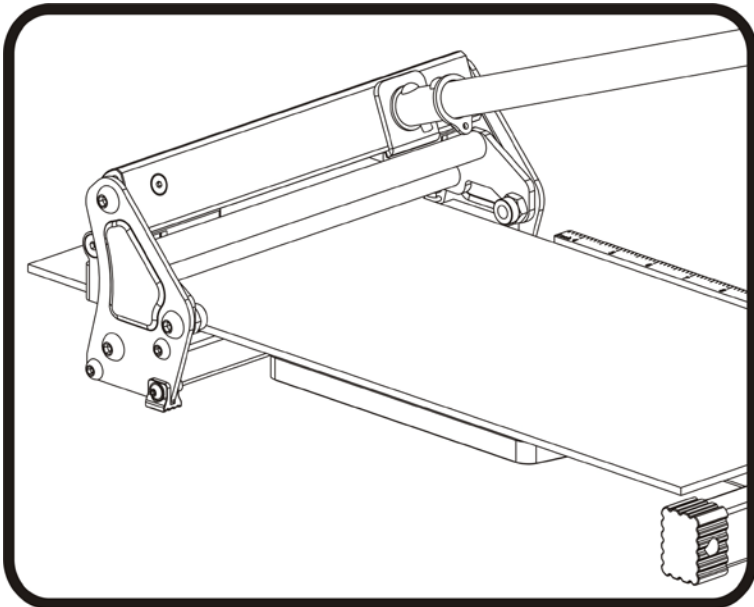

### Cut

Insert material between the cutting blade and the base, flush with the gauge as shown and hold the material then push handle down to complete a cut.

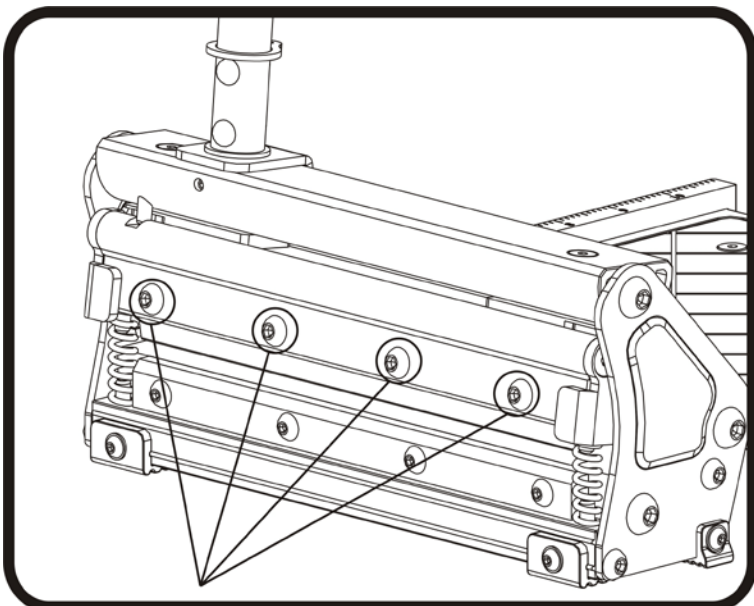

### Changing the Blade

Use the provided Allan wrench to remove the four screws, then hold the blade by each end and carefully move the blade out of blade holder.

**Note:** the flat side of the blade facing the table.

**Warning:** Do not put your fingers against the sharp edge of the blade at any time.

# Part List

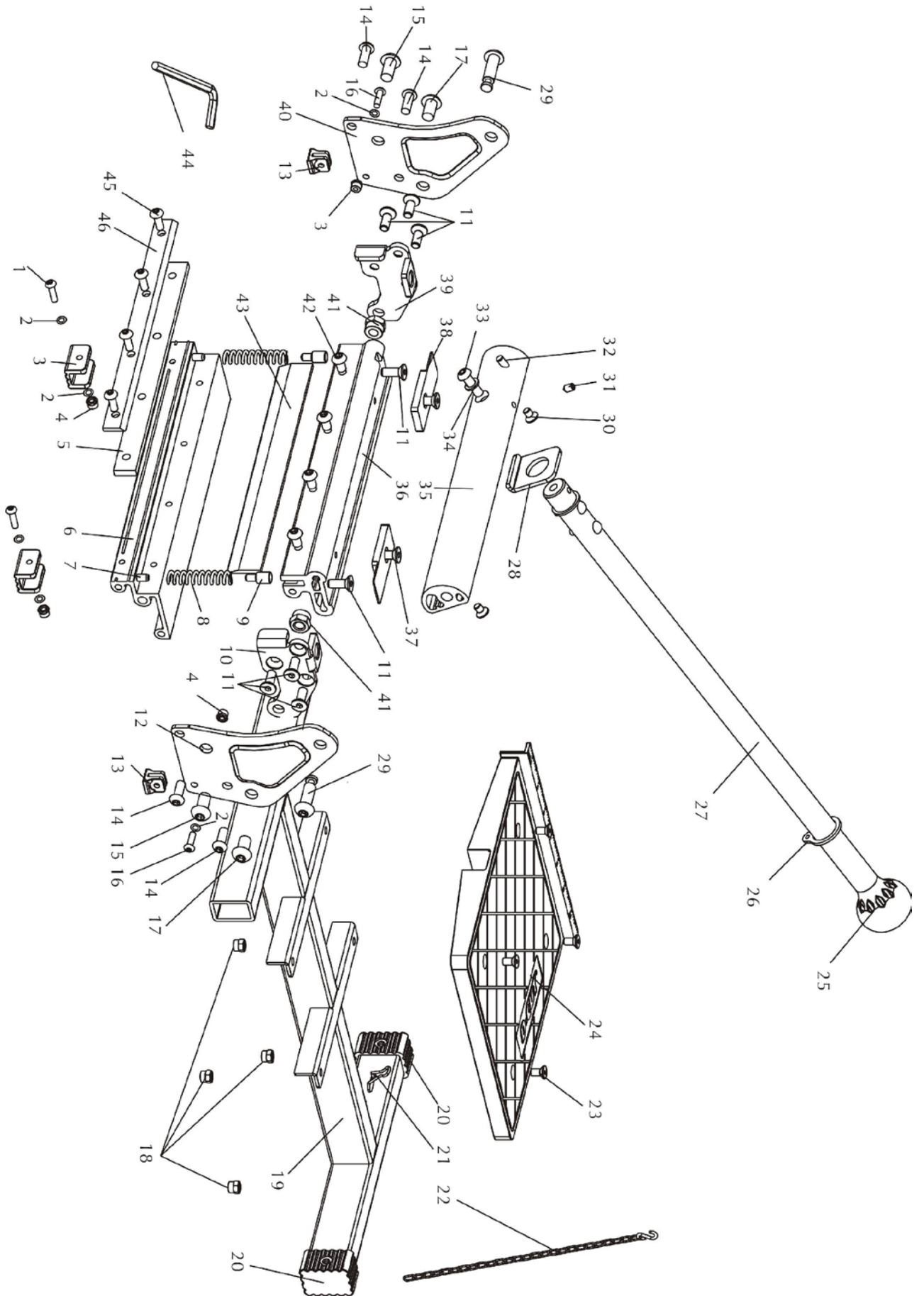

	Parts	Q'ty		Parts	Q'ty
1	Hex Head Screw M4 × 25	2	24	Working Table	1
2	Washer $\phi 4$	6	25	Ball Handle	1
3	Rubber Feet A	2	26	Hook B	1
4	Lock Nut M4	4	27	Handle	1
5	Nylon Block	1	28	Stopper	1
6	Cutter Base	1	29	Rotating Shaft	2
7	Spring Pin	2	30	Hex Head Screw M5 × 8	2
8	Spring	2	31	Hex Headless Screw M5 × 8	1
9	Pin	2	32	Parallel Pin	1
10	Left End Plate	1	33	Hex Head Screw M6 × 20	1
11	Hex Head Screw M6 × 16	8	34	Spring Washer	1
12	Left Side Plate	1	35	Aluminum Eccentric Cam	1
13	Rubber Feet B	2	36	Blade Holder	1
14	Hex Button Head Screw M6 × 16	4	37	Hex Head Screw M5 × 16	2
15	Hex Button Head Screw M8 × 16	2	38	Nylon Board	2
16	Hex Button Head Screw M4 × 16	2	39	Right End Plate	1
17	Customized Screw M5	2	40	Right Side Plate	1
18	Lock Nut M5	4	41	Lock Nut M8	2
19	Working Table Base	1	42	Hex Head Screw M6 × 8	4
20	End Cap	2	43	Blade	1
21	Hook A	1	44	Allan Wrench M6	1
22	Chain	1	45	Hex Head Screw M5 × 16	4
23	Hex Head Screw M5 × 10	4	46	Hold Bar	1