

D-CUT[®]

OPERATION MANUAL

Hand Cutter HC-040

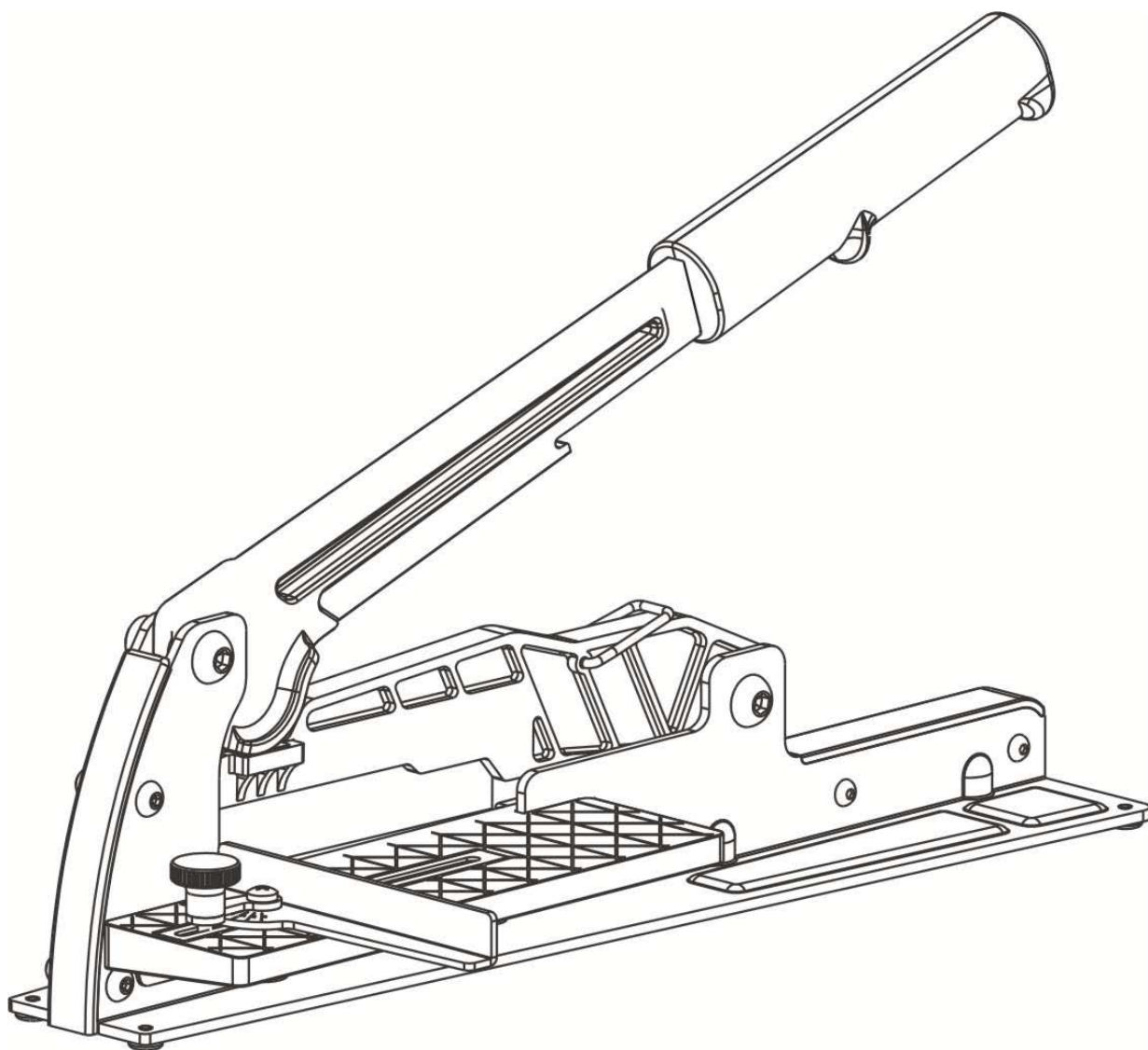

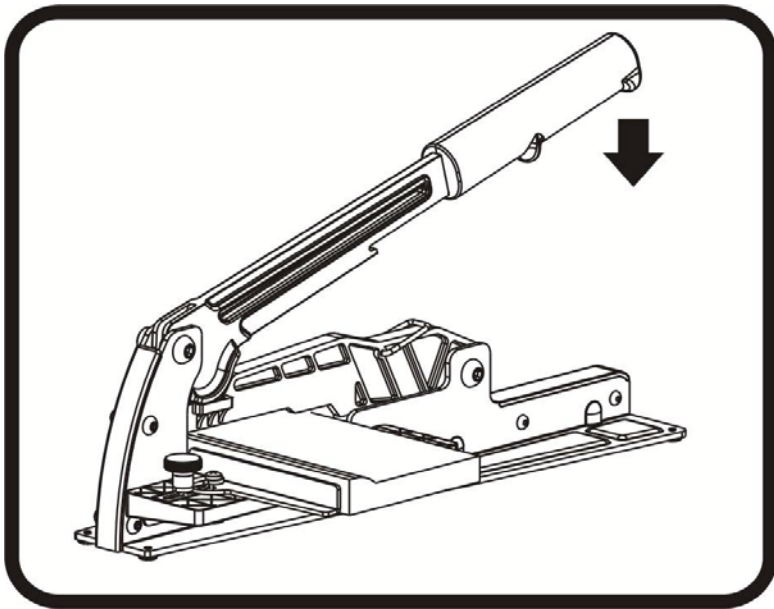

Regular Cutting

Place the work-piece under the blade and press down the handle to complete the cut as shown.

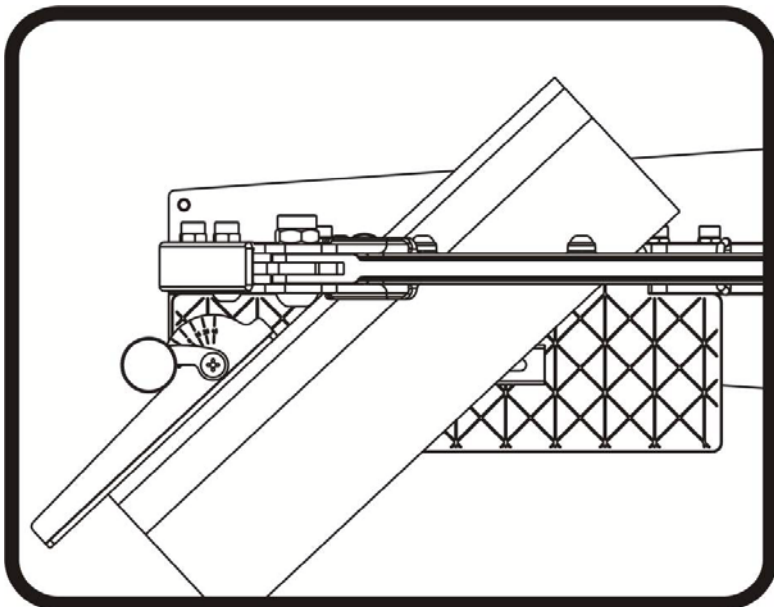

Angle Cutting

Adjust the angle attachment to the desired angle and lock it. Place the work-piece under the blade and press down the handle to complete the cut as shown.

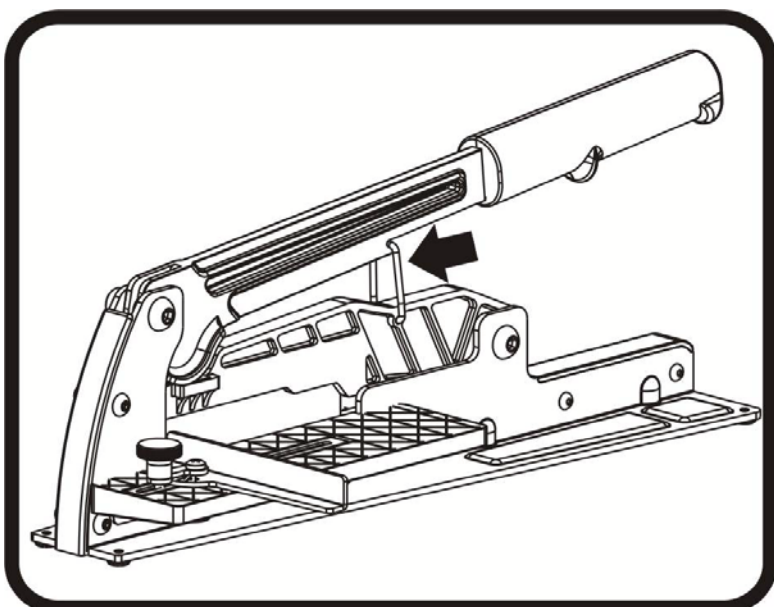

Lock for storage

Lock the handle as shown for transportation and storage.

Part List

	Parts	Q'ty		Parts	Q'ty
1	Left Base	1	15	Hex Screw M8 × 25	2
2	Rubber Foot Pad	4	16	Hook	1
3	Hex Screw M5 × 20	2	17	Blade Base	1
4	Face board	1	18	Blade	1
5	Locker Nut M5	2	19	Reset Spring	1
6	Sleeve	1	20	Right Base	1
7	Stainless Steel Pad	2	21	Spacer Block	1
8	Screw M4 × 8	3	22	Hex Screw M4 × 20	5
9	Locker Nut M4	5	23	Knurled Screw	1
10	Locker Nut M8	2	24	Cross Head Screw M4 × 6	1
11	Screw ST3.5 × 22	2	25	Working Table	1
12	Right Handle	1	26	Angle Attachment	1
13	Handle	1	27	Sliding block	1
14	Left Handle	1	28	pointer	1