

# D-CUT<sup>®</sup>

## OPERATION MANUAL

---

Vinyl Wall-base Cutter RC-200

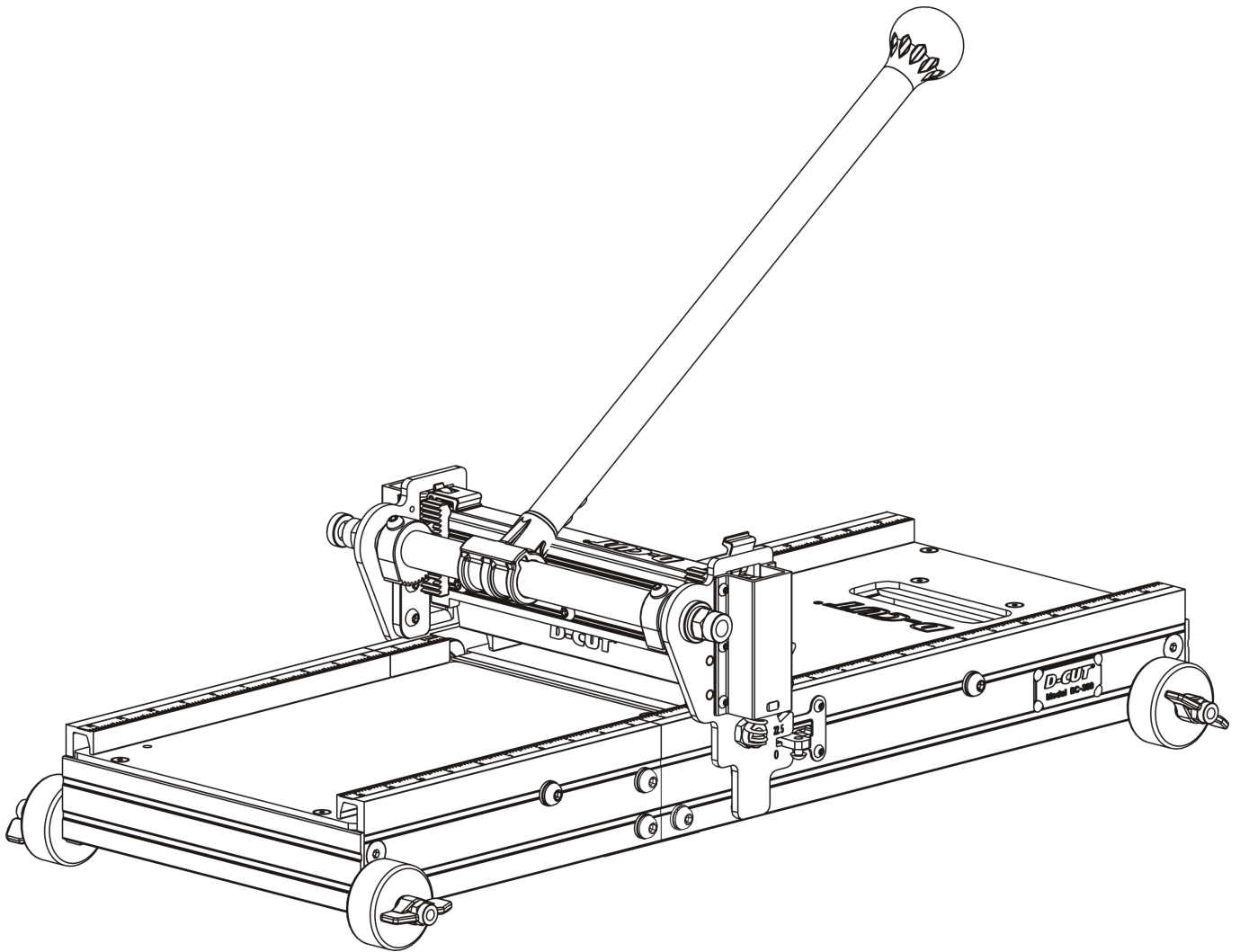



**WARNING: FAILURE TO FOLLOW THESE RULES MAY RESULT IN SERIOUS INJURY! USING THIS MACHINE WITH RESPECT AND CAUTION WILL CONSIDERABLY LESSEN THE POSSIBILITY OF PERSONAL INJURY.**

---

## **SAFETY RULES FOR THE FLOORING CUTTER**

- 1. READ AND UNDERSTAND THIS INSTRUCTION MANUAL BEFORE OPERATING THE MULTI-FLOORING CUTTERS.**
2. If you are not thoroughly familiar with the operation of Multi-flooring Cutter, obtain advice from a qualified instructor or call 630-916-9100 USA
3. Stay alert. Do not operate while under the influence of drugs, alcohol, or medication.
4. Always wear safety approved eye protection with side shields(ANSI Z87.1)
5. Keep work area free of debris.
6. Keep children and unauthorized persons away from the Multi-flooring Cutter and work area.
7. Make sure tool is secure. Operate only on a firm substrate or solid stand.
8. Use the right tool. Do not force the Multi-flooring Cutter or use it for a job for which it was not designed; use only on approved materials.
9. Keep the blade sharp. A dull blade will not perform properly.
10. Always keep hands away from blade while operating or carrying the cutter.
11. Do not alter or misuse this tool. The Multi-flooring Cutter is precision built; modifications not specified in this manual may result in a dangerous and unsafe environment.
12. Maintain the Multi-flooring Cutter with care. Keep Blade sharp and clean. Follow instructions for changing accessories.
13. Use only recommended accessories. The use of improper accessories may be hazardous and cause injuries.
14. Never leave the Multi-flooring Cutter unattended. Secure the handle with the lock chain when not in use.

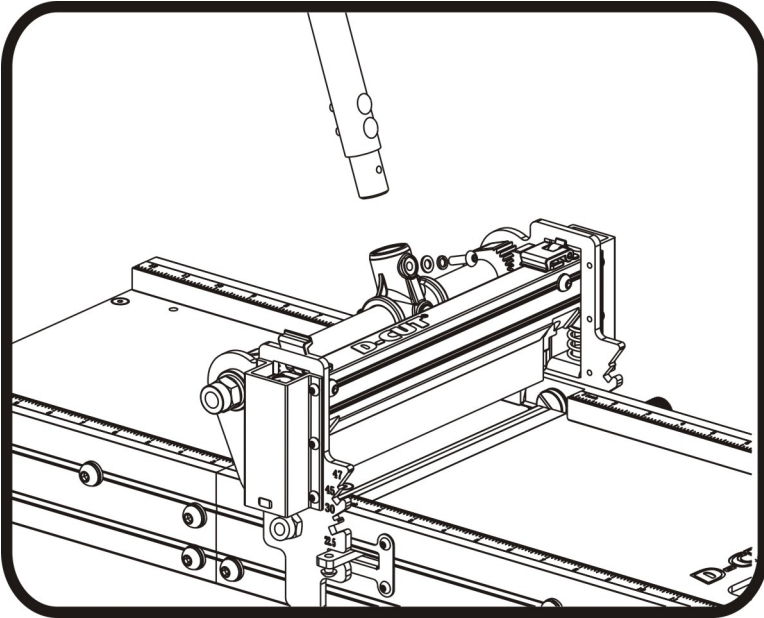

### Handle Assembly

Insert the handle to the handle base and use the provided screw/ washer /spring washer to secure as shown.

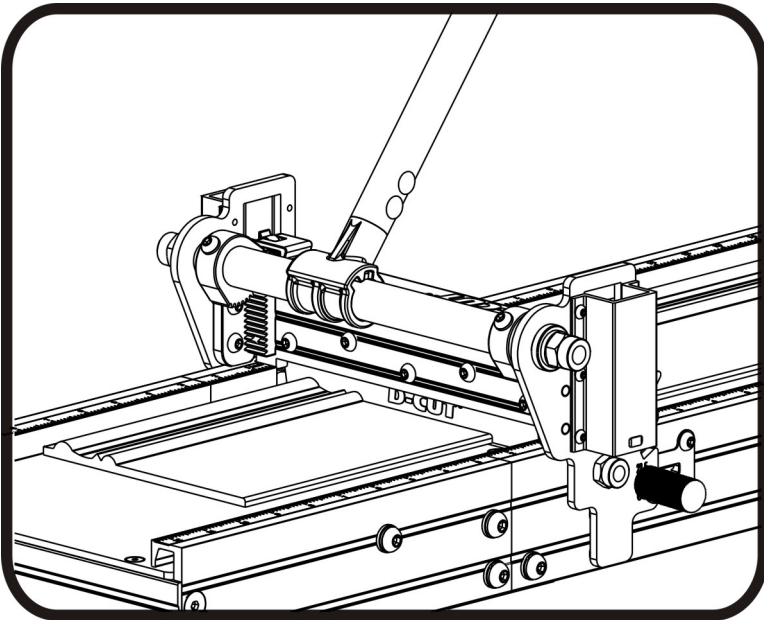

### Straight Cut

Place the work-piece flush with either side of the guide bar on the working table and align the blade to the mark on the work-piece where needs to be cut. Then press the handle down to complete the cut.

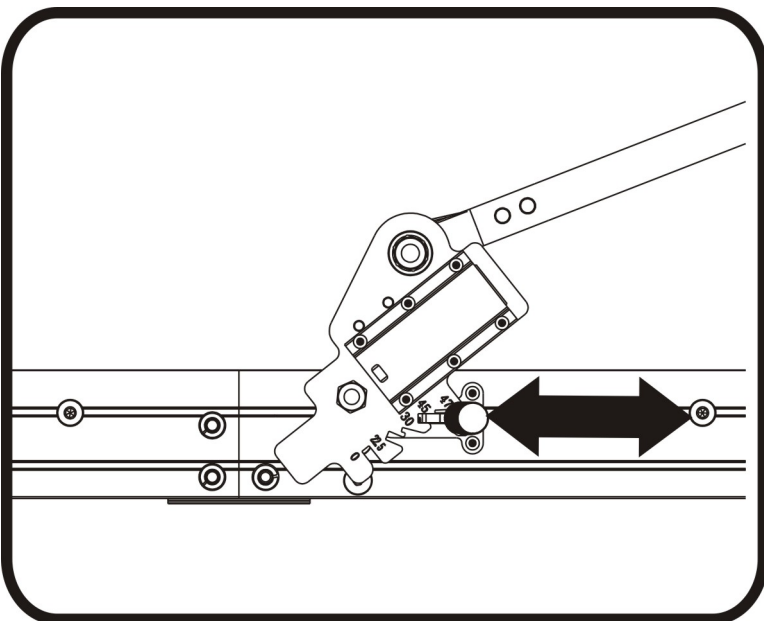

### Bevel Cut (1)

There are five slots on the handle base as shown. One of them is for straight cut and other two are for bevel cuts. Pull the knob out of the angle slot on the swing head and release the knob to the desired angle slot as shown.

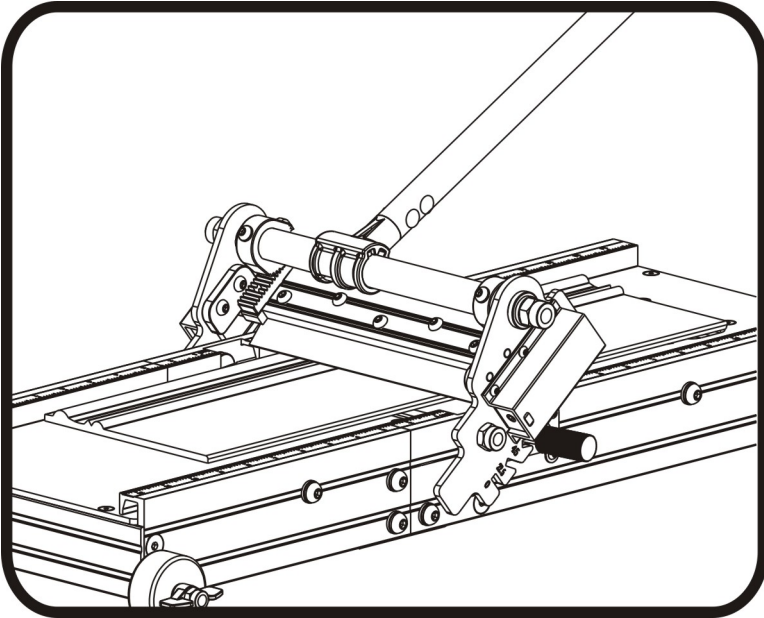

### Bevel Cut (2)

Place the work-piece flush with either side of the guide bar on the working table and align the blade to the mark on the work-piece where needs to be cut. Then press the handle down to complete the cut.

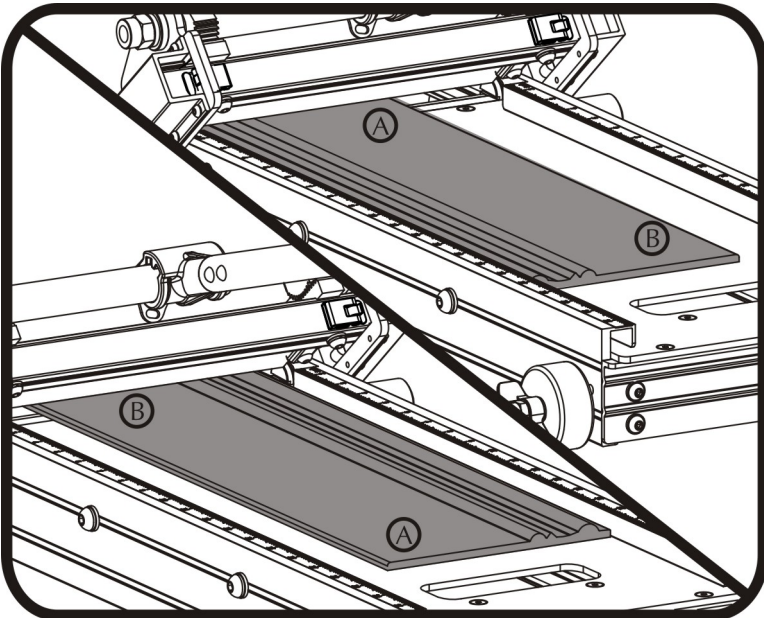

### Bevel Cut (3)

Place the work-piece flush with either side of the guide bar on the working table and make a cut to get a half inside corner and a half outside corner. Then turn the work-piece around and place it flush with other side of the guide bar, then make the second cut to get another half inside corner and another half outside corner.

**Note:** Keep the flat part of the work-piece down towards the working table.

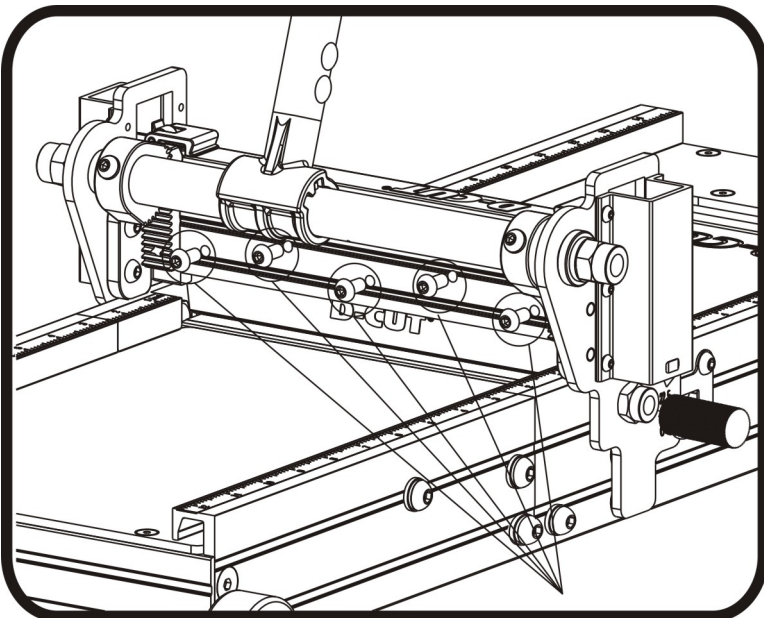

### Changing the Blade

Use provided Allan wrench to remove the five screws as shown, then hold the blade by each end and carefully remove the blade out of the blade holder.

**Note:** when putting a new blade on, keep the flat side of the blade facing the main table.

**Warning:** Do not put your fingers against the sharp edge of the blade at any time.



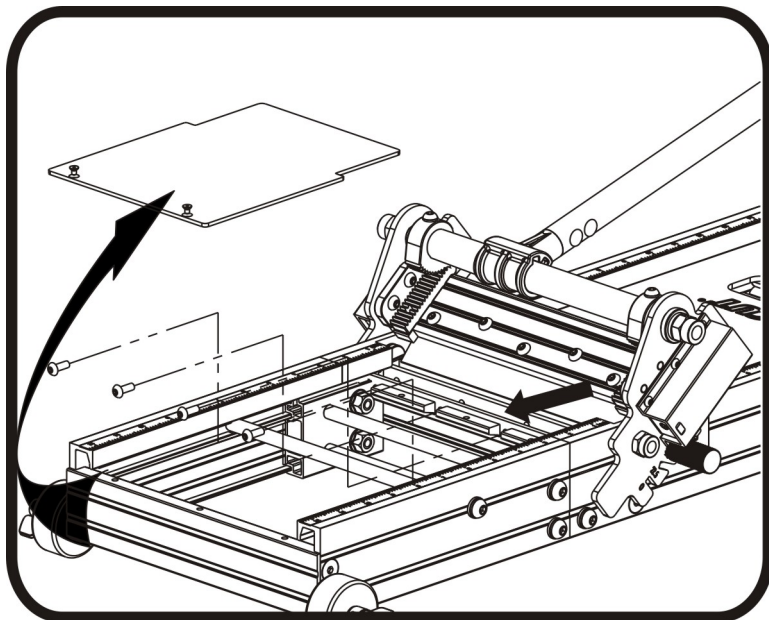

### Changing the Nylon Base

Use provided Allan wrench to take off total 2 screws to remove the working table, then take off the four screws as shown to replace the nylon board when it is necessary.

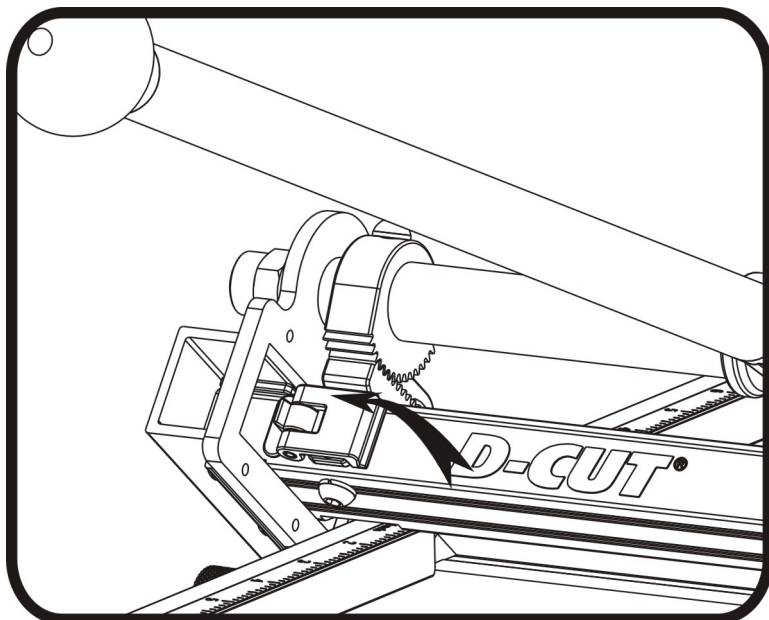

**When the cutter is not in use, you need to keep the blade in a close position for the safety.**

1. Turn the cutting head to 45° .
2. Press the handle down to make the blade in a close position
3. Lift the device on the top of the blade holder to hold the blade holder from coming up

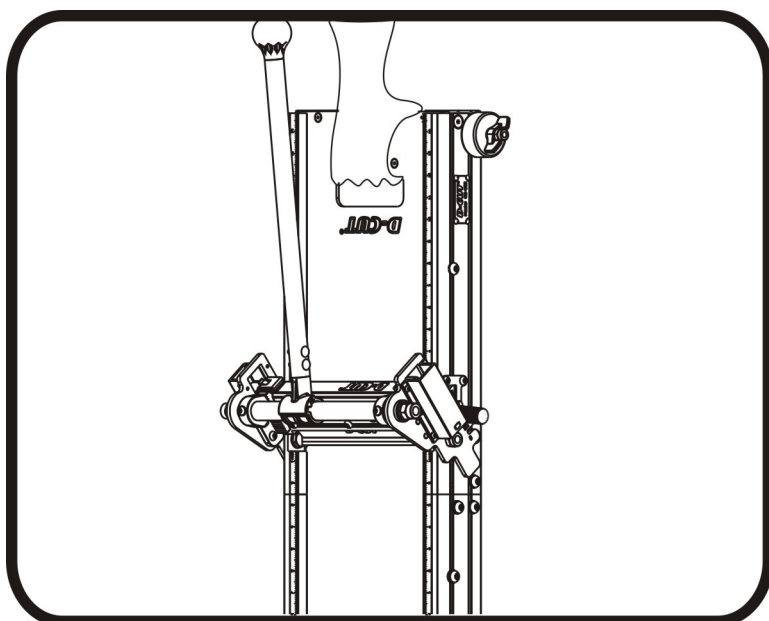

### Transportation and Storage

carry or store the cutter as shown.

# Explosive View

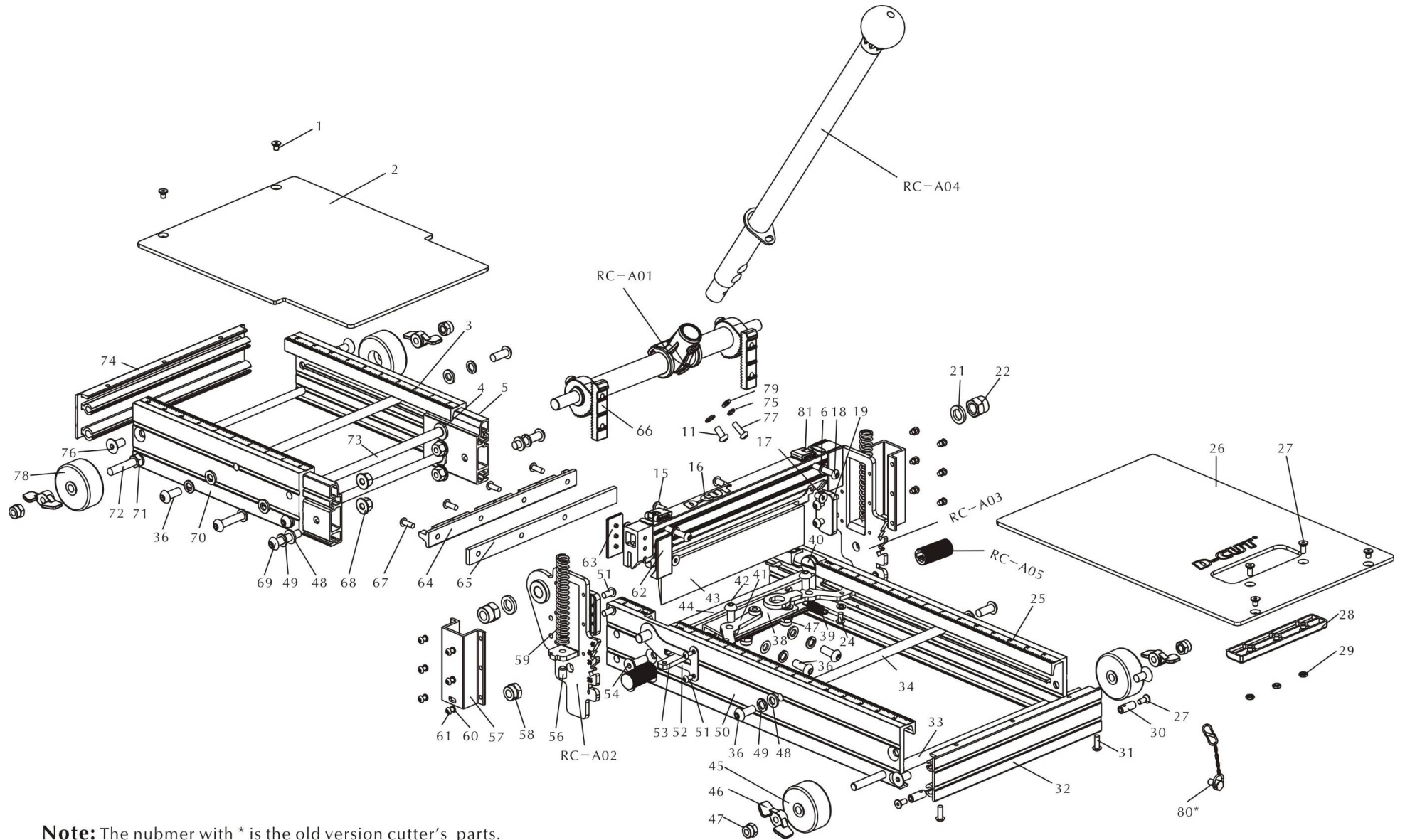

**Note:** The number with \* is the old version cutter's parts.

**Partial Enlarged View**

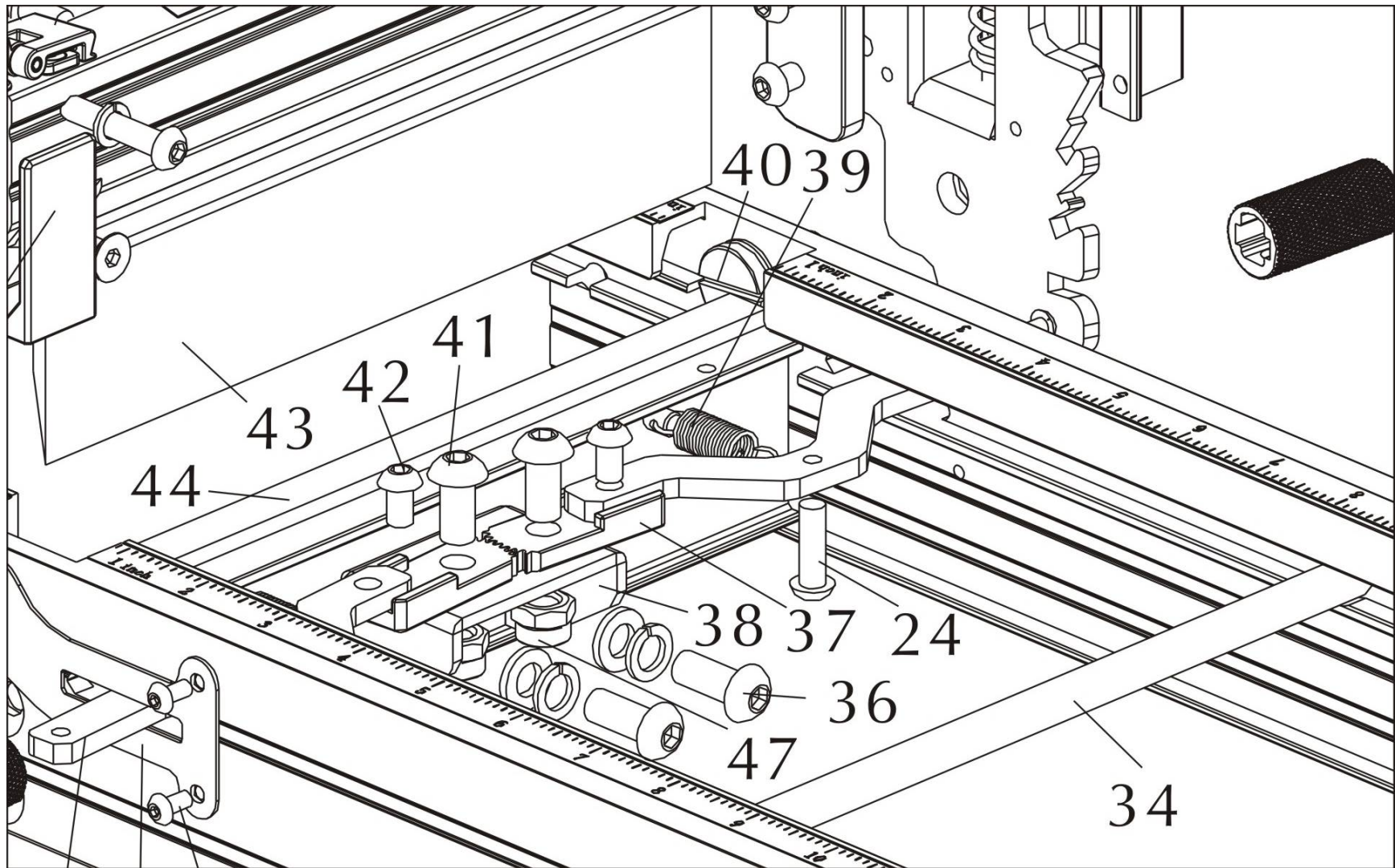

# Part List

	Parts	Q'ty		Parts	Q'ty
RC-A01	Gear Assembly	1	43	Blade	1
RC-A02	Left Rotation Plate Assembly	1	44	Cutter Base	1
RC-A03	Right Rotation Plate Assembly	1	45	Rear Wheel	2
RC-A04	Handle Assembly	1	46	Wing Nut	4
RC-A05	Angle Handle Assembly	2	47	Lock Nut M8	6
1	Screw M5 x 8	4	48	Washer $\phi$ 8 x 2	13
2	Front Working Table	1	49	Spring Washer $\phi$ 8 x 1.6	13
3	Frame A	1	50	Frame D	1
4	Washer $\phi$ 8x 1.5	4	51	Screw M6 x 12	5
5	Working Table Connection	2	52	Lining Board	2
11	Screw M6 x 12	1	53	Angle Position Shaft	2
12	Handle Stop	2	54	Steel Slot	2
15	Hex Screw M6 x 12	2	56	Screw M8 x 12	2
16	Blade Base	1	57	Spring	2
17	Hex Screw M6 x 14	2	58	Lock Nut M10	2
18	Bolt M6 x 32	2	59	Cover	2
19	Nylon Stop	2	60	Washer $\phi$ 4 x 0 .8	12
20	RC-A03	1	61	Screw M4x 8	12
21	Washer $\phi$ 12 x 3	2	62	Nylon Cover A	2
22	Lock Nut M12	2	63	Nylon Cover B	2
24	Screw M5 x 10	6	64	Nylon Bar Holder	1
25	Frame A	1	65	Nylon Bar	1
26	Rear Working Table	4	66	Gear Rib	2
27	Screw M5 x 12	4	67	Screw M5 x 14	4
28	Carry Handle	1	68	Lock Nut M8	8
29	Nut M5	3	69	Screw M8 x 37	7
30	Pin with internal thread	2	70	Frame E	1
31	Screw M5 x 14	2	71	Nut M8	1
32	Frame C	1	72	Front Wheel Shaft	1
33	Rear Wheel Shaft	1	73	Cross Bar B	2
34	Cross Bar A	2	74	Frame F	1
35	Nut M8	2	75	Screw M8 x 16	4
36	Screw M8 x 20	6	76	Front Wheel	2
37	Sector Gear	2	77	Screw M5 x 16	1
38	Rotation Base	1	78	Screw M8 x 16	2
39	Tension Spring	2	79	Washer $\phi$ 5	1
40	Rotation Shaft	2	80*	Chain Assembly	1
41	Screw M8x 16	2	81	Cutting Head Stopper Assembly	1
42	Cup head Screw M6x 10	2			